

Yingli Module---General Installation Manual

You shall read this manual before installing or using Yingli modules (simplify Yingli module).



英利能源（中国）有限公司

YINGLI ENERGY (CHINA) COMPANY LIMITED
Add: NO 3399 Chaoyang North Road, Baoding China (071051)
Tel: +86(312)8929700 Fax: +86(312)3151881
Http://www.yinglisolar.com Email:yingli@yinglisolar.com

INTRODUCTION

Thank you for purchasing Yingli Photovoltaic (PV) modules. This manual contains important installation, maintenance and safety information. Retain this instruction for future reference.

Disclaimer of Liability

Yingli does not assume responsibility and expressly disclaims liability for loss, damage, or expenses arising out of, or in anyway connections with installation, operation use or maintenance by using this manual. Yingli assumes no responsibility for any infringement of patents or other rights of third parties, which may result from using of the module. No license is granted by implication or under any patent or patent rights. The information in this manual is believed to be reliable, but does not constitute an expressed and implied warranty. Yingli reserves the right to make changes to the product, specifications, or manual without prior notice.

General Information and safety

The installation of solar modules requires by qualified licensed professional, including, without limitation, licensed contractors and licensed electricians.



- Instructions shall be read and understood before attempting to install, wire operate and maintain the photovoltaic module. Contact with electrically active parts of the module such as terminals can result in burns, sparks, and lethal shock whether the module is connected or disconnected.
- PV modules generate DC electricity when exposed to sunlight or other light sources. Although single module produces only a low voltage and current, shocks and burns may still occur.
- To avoid the hazard of electric shock and injury, cover all of the front surface of PV modules with material such as the cardboard box during installing and handling.
- Do not step on a module in which can cause the damage.
- Damage the back sheet of a module can cause the potential electric shocks and fire.
- Children and unauthorized persons should not be allowed near the PV modules during the installation.
- Do not disassemble or remove any part of a module that installed by the manufacturer.
- Only the qualified professional should open the junction box and to replace the bypass diodes.
- Do not touch terminals while a module(s) is exposed to light.
- At least two persons should carry a module wearing non-slip gloves.
- Do not carry a module by holding the wires or the junction box.
- Do not drop any object on the surfaces of module avoiding to cause the damage.
- Avoid flammable gases or solvents to be present during the installation.

INSTALLATION

- Make sure the modules are arranged such that the current and voltage characteristics of the array are within the tolerances of the device to which the array will connect. Use this module in systems of up to 1000 volts (US NEC Rating: 600V) .
 - In actual usage, a photovoltaic module may experience conditions that result in more current and/or voltage than reported at standard test conditions. The module's Isc rating should be multiplied by a factor of 1.25 when determining component ratings. NEC 690.8 requires an additional multiplying factor of 1.25 for conductor and fuse sizing. Refer to NEC Table 690.7 for voltage correction factors that are based on ambient air temperatures. If NEC Table 690.7 is not available, a factor of 1.25 should be used to adjust voltage.
 - The maximum Mechanical Loading shall be 30lb/ft².
 - Recommended Tilt Angles for stand alone system according to diagram 1.
- Recommended Tilt Angles equal to the site's latitude for the grid-connected system.
- Installation shall be in accordance with CSA C22.1, Safety Standard for Electrical Installations, Canadian Electrical Code, Part 1 .

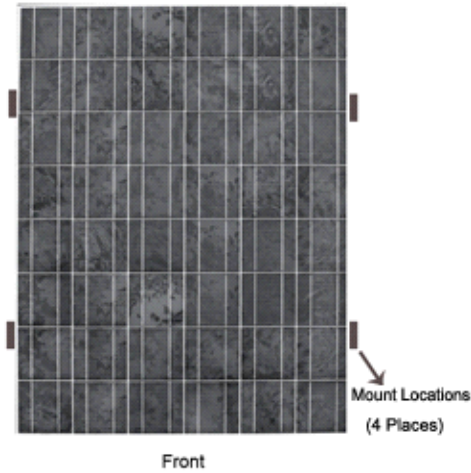

ig. 1

Table 1.	
Recommended Tilt Angles	
Site Latitude in Degrees	Fixed Tilt Angle
0° to 15°	15°
15° to 25°	Same as latitude
25° to 30°	Latitude plus 5°
30° to 35°	Latitude plus 10°
35° to 40°	Latitude plus 15°
40°	Latitude plus 20°

Diagram 1

Before Installation

- To comply with NEC, a minimum of four inches clearance between the module frame and the mounting surface is required. The module shall never be sealed to the mounting surface with sealant that prevents air from circulating under the module.
- The module shall be installed as shown in figure 1. Failure to do so can lead to the frame separating from the glass, the glass breaking, and/or the solar module may become a falling object.
- The corrosion resistant material should be used as installation hardware.

Installation

- Follow the illustration in figure 1 to provide proper support of the module that will withstand all expected loads, including those imposed by snow, ice, or wind.
 - Module should be mounted facing south. In general, the modules will lose approximately 10 to 15 percent of their power output if they are facing 30 degrees away from true South. 20 to 30 percent of power will be lost if the modules are facing 60 degrees away from true South. For more information, refer to table 1.
 - Modules shall be installed where they are not shaded by the obstacles or partially shaded by any objects.
 - Modules should be bolted to support structures through mounting holes located in the frame's back flanges. The frame of each module has four 6 mm diameter mounting holes. It is required to use a cutting star washer, stainless steel screws, and bolts to secure the mounting. The use of a copper washer is not permitted due to the possibility of causing corrosion through the use of dissimilar metals. Creating additional holes or mounting is not permitted and will invalidate the warranty.
 - Modules should be mounted so that the junction box will be in the upper most position to minimize the ingress of water.
- In case the modules are mounted on the roof or wall of a building, either standoff method or the rack method is required.
- a) **Stand off:** The modules should be supported parallel to the surface of the building wall or roof. A minimum clearance of 4.0 inches (102 mm) between the module frame and the surface of the wall or the roof is required to allow air to circulate behind the module and

to prevent wiring damage.

b) **Rack:** The supporting module frame is used to mount the module at correct tilt angles. The mounting design may have an impact on the fire resistance.

• Be aware if other mounting method employed, it may affect for Fire Class Ratings.

• **Caution: DO NOT connect the modules to the regulator, battery, or load at this time.**

• If the system involves regulator and battery, refer to the manufactures procedures for the battery and regulator wiring. After the battery and regulator/load are wired, connect the system with the following procedure:

1. Connect the regulator to the battery
2. Connect the regulator to the module output
3. Connect the load to the regulator

Wiring

Yingli series modules come pre-wired and terminated ready for most building attached or free standing installations.

Each module has two stranded sunlight resistant output cables each terminated. The positive (+) terminal has a female connector while the negative (-) terminal has a male connector. The module wiring is solely for series connections only, i.e. female (+) to male (-) interconnections. Series and parallel connections shall be made by use of two #12 AWG sunlight resistant output cables with male and female connectors. (UL Listed: Yingli series modules have a maximum system voltage rating of 600 volts DC. You shall refer to the National Electrical Code Article 690-7(a) for determining the maximum number of Yingli series modules that can be placed in series.)

Grounding: Before installing your solar system, contact local authorities to determine the necessary grounding. (UL Listed: Attach all module frames to an earth ground in accordance with the National Electrical Code (NEC).) Proper grounding is achieved by connecting the module frame(s) and structural members contiguously one to another using a suitable copper grounding conductor. The grounding conductor must make a connection to earth using a suitable earth ground electrode. Ensure positive electrical contact through the anodizing (coating) on the module's frame for reliable bonding by attaching the copper grounding conductor to one of the 6 mm diameter holes marked 'ground' using two stainless steel Cupped washers (Ø6), tooth washer (Ø6), a bolt (M6 × 30), and a nut (M6), with a torque value of (7N.M).

Illustration about Grounding Method:

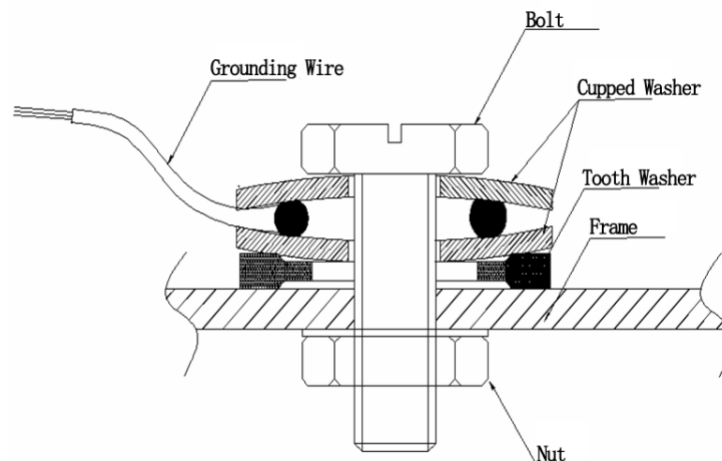

• **Bypass Diodes:** Partial shading of an individual module in a series can cause a reverse voltage to travel across the shaded module; the current is then forced through the shaded area by the other modules in series. Bypass diodes can minimize module heating and array current losses by forced current bypass the shaded module in a series circuit. All Yingli modules are equipped with factory installed bypass diodes. The factory-installed diodes provide proper circuit protection for the systems, therefore no additional bypass diode(s) is(are) needed. Contact your authorized Yingli distributor or dealer for proper diode type, if necessary to add or change diodes due to the system requirement.

Maintenance

Some maintenance is recommended to maintain optimal output performance of solar cell modules. Do not clean modules during the middle of the day when the glass is hot. The thermal shock of cold water on hot, tempered glass could shatter the glass. If the module surface becomes dirty, it may cause reduction of output power. It is recommended to clean the surface with water and soft cloth or sponge. A mild non-abrasive detergent may be applied for the persistent dirt. And it is also recommended to inspect the electrical and mechanical connections annually. If you need electrical and mechanical inspection or maintenance, it is recommended to have the authorized professional carry out the inspection or maintenance to avoid the hazards of electric shock or injury.

Return policy

The return of any modules will not be accepted by Yingli unless prior written authorization has been given by Yingli. As part of our Yingli solar

policy of continuous improvement Yingli reserves the right to change products specifications at any time without prior notice.

Mechanical / Electrical Specifications

Module Type	YL180(23)P	YL175(23)P	YL170(23)P	YL165(23)P	YL160(23)P	YL155(23)P	YL150(23)P
Rate Watts (Pmax)	180	175	170	165	160	155	150
Max. Volt (Vpmax)	23V	23V	23V	23V	23V	22.5V	22.5V
Max. Current (Ipmax)	7.83A	7.61A	7.39A	7.17A	6.96A	6.89A	6.67A
Open Circuit (Voc)	29.5V	29V	29V	29V	29V	29V	29V
Short Circuit (Isc)	8.3A	8.2A	8.1A	7.9A	7.7A	7.4A	7.2A
Max. Voltage	1000V	1000V	1000V	1000V	1000V	1000V	1000V
Length, (mm)	1310	1310	1310	1310	1310	1310	1310
Width, (mm)	990	990	990	990	990	990	990
height, (mm)	50	50	50	50	50	50	50
Weight (Kg)	15.8	15.8	15.8	15.8	15.8	15.8	15.8

The above values are measured at Standard Test Conditions (STC), 1000W/m², 25°C cell temperature and AM 1.5G. Power tolerances are +/- 3% unless noted otherwise

Module Diagram

Dimensions are in millimeters

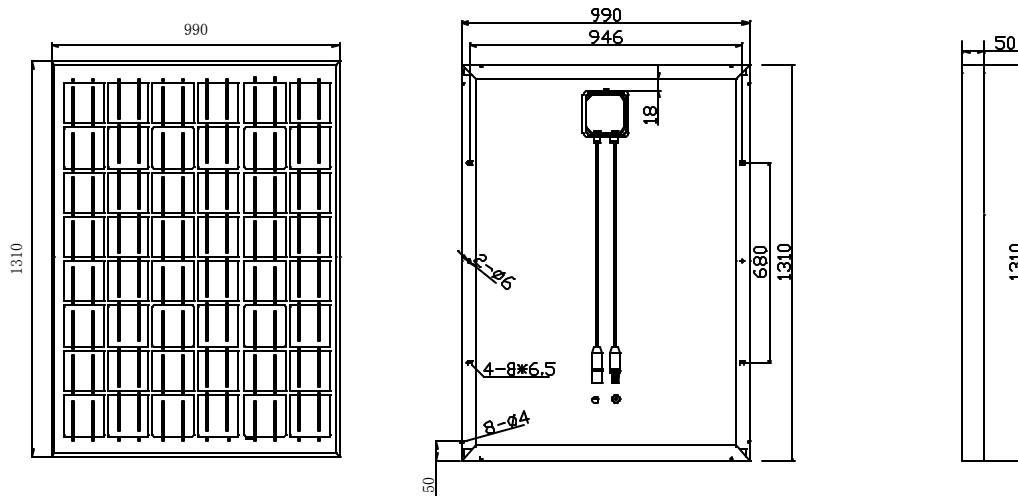

Tel: +86(312)8929700 Fax: +86(312)3151881
 Http://www.yinglisolar.com Email:yingli@yinglisolar.com
 Add: NO 3399 Chaoyang North Road, Baoding China (071051)