

Reliable system – high yields. Bosch Solar Module μ m-Si

High-yield – easy-to-assemble – reliable.
Solar modules from Bosch Solar Energy.

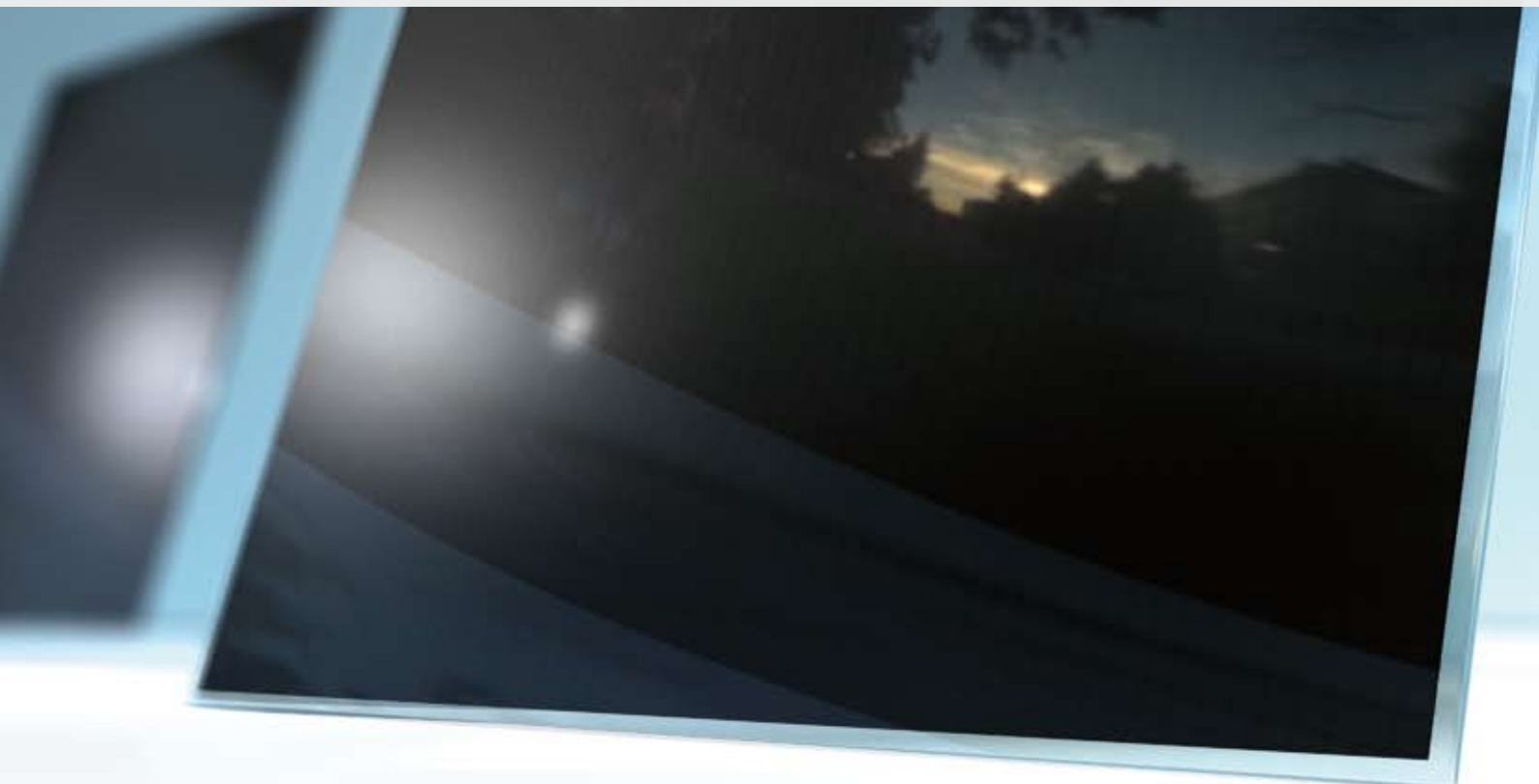

BOSCH



Our thin-film modules offer impressive features including:

- ▶ Excellent annual yields for you and your customers, using non-toxic materials
- ▶ Assembly systems that complement one another perfectly and are supplied from a single source thanks to collaborations with major assembly system manufacturers, including Bosch Rexroth
- ▶ Straightforward, solid installation with low assembly outlay through adaptability of recognized standard components
- ▶ Good usage options on e.g. east-facing, west-facing and slightly sloping roofs

Warranty conditions:

- ▶ 2-year product warranty
- ▶ Performance guarantee based on our guarantee conditions
- ▶ Product certification to IEC 61646 and IEC 61730

Length [x]	Width [y]	Height [z]	Weight	Junction box	Plug connector	Cable
1300	1100	7.1	25	MultiContact	MC4	Plus 600 Minus 1000
x, y in mm, -1 / +3 mm; z in mm, ± 0.5 ; weight in kg ± 0.7						

Thin-film solar module	
Performance classes	100 Wp, 105 Wp, 110 Wp, 115 Wp
Performance sorting	± 2.5 Wp
Structure	Frameless glass-glass laminate <ul style="list-style-type: none"> ▶ Float glass ▶ PVB or EVA foil ▶ Thermally strengthened rear glass ▶ Junction box with bypass diode ▶ IP-Code Junction Box (IP 65)
Cells	Microcrystalline silicon Multi-junction cell

Electrical characteristics for STC:**

Performance class [Wp]	Vmpp [V]	Impp [A]	Voc [V]	Isc [A]	Voc initial [V]	Isc initial [A]
100	98	1.02	129	1.34	131	1.37
105	100	1.05	131	1.37	133	1.39
110	102	1.08	133	1.40	135	1.42
115	104	1.11	135	1.44	137	1.46
Reduction in module efficiency with decrease in irradiation level from 1000 W/m ² to 200 W/m ² (at 25 °C): -0.XX% (absolute)						

Electrical characteristics for NOCT*:

Designation	Pmpp [W]	Vmpp [V]	Voc [V]	Isc [A]
NOCT: Normal Operation Cell Temperature 48.4 °C: Irradiation level 800 W/m ² , AM 1.5, temperature 20 °C, wind speed 1 m/s, electrical open circuit operation				

Dimensions*:

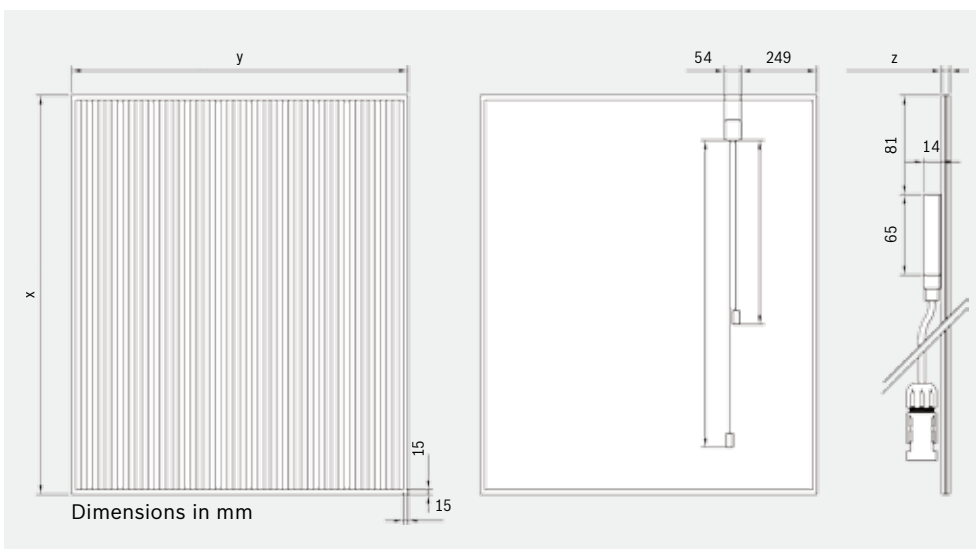

* Drawings and diagrams are not to scale. Detailed dimensions and tolerances are available on request.

** Electrical parameters are typical mean values from historical production data.
Bosch Solar Thin Film GmbH assumes no liability for the accuracy of this data for future production batches.
All data is subject to a measuring tolerance of $\pm 3\%$.

Permissible operating and assembly conditions:

- ▶ Temperature range -40 °C to +85 °C, humidity max. 85 % (rh)
- ▶ Upright assembly, laser lines running vertically
- ▶ Mechanical load capacity tested on the basis of the "General information and guidelines for fastening Bosch Solar Module $\mu\text{-Si}$ with loads of up to 2400 Pa."
- ▶ Transformerless DC-AC converters are not permitted
- ▶ Maximum 1000 V system voltage

Weak light performance:

Intensity [W/m ²]	Vmpp [%]	Impp [%]
1000	0.0	0
800	-1.0	-19
600	-2.0	-39
400	-3.0	-59
200	-8.0	-80
The electrical data applies for 25 °C and AM 1.5.		

Thermal characteristics:

Temperature coefficient Pmpp	-0.25%/K
Temperature coefficient Voc	-0.31%/K
Temperature coefficient Isc	+0.05%/K
NOCT	

Bosch Solar Thin Film GmbH
 Sonnentor 2
 99098 Erfurt
 Germany
 Phone: +49 361 74376-100
 Fax: +49 361 74376-199
sales.se@de.bosch.com
www.bosch-solarenergy.de